



## The Impact of Brand Personality and Students' Self-Concept on Brand Engagement

Stephen Banahene<sup>1</sup>

### ABSTRACT

The objective of this study is to investigate how brand personality and customers' 'self' affects brand engagement. This has become necessary because the focus of most research into brands has often neglected how brand personality and customers' 'self' can be harnessed to achieve brand engagement. This study used Aaker's brand personality, Keller's brand engagement, and Sprott et al. self-concept measurement scales. The research methodology includes the following steps: adaptation of the measurement scales to suit the research context, assessment of reliability and validity of dimensions, and test of goodness-of-fit of model. In all 252 valid responses out of 302 questionnaires distributed were used for the study. The research found that brand personality and customers' 'self-concept' have positive effect on brand engagement. Sincerity has negative relationship with brand engagement and self-concept whiles hedonism has negative relationship with self-concept only. Competence, sophistication and excitement dimensions have significant effects on customers' self-concept and brand engagement. Sincerity and hedonism also have negative effects on self-concept and brand engagement. Competence, sophistication and excitement can be used as differentiate strategy by Private Universities to deal with the growing competition in Ghana. The findings suggest that Private Universities can differentiate themselves by developing brand personality that is competent and exciting, whereby they can successfully engaged their customers. The authors' investigations also suggest that self-concept can be measured by splitting Sprott et al measurement scale into two (self-congruence and value-congruence). In the same way, brand engagement can be measured by splitting Keller's measurement scale into two (identification and ambassador dimensions) for theoretical insight. In addition, hedonism has been identified as a useful measure of brand personality but not clear with faith-based Private Universities' brand personality. Private Universities' differentiation strategy should be based on competence, sophistication and excitement.

**Keywords:** Brand Personality, Brand Engagement, Hedonism, Self-Concept, Value-Congruence.

**JEL Codes:** M31, M37 and D91.

This is an open access article under [Creative Commons Attribution 4.0 License, 2017](https://creativecommons.org/licenses/by/4.0/).

### 1. Introduction

The corporate vision has changed from one where only tangible assets had value to one where organisations now believe that their most important asset is their intangibles, like brands and patents

<sup>1</sup> Senior Lecturer, School of Business, Christian Service University College, Ghana, [Sbanahene@Csuc.Edu.Gh](mailto:Sbanahene@Csuc.Edu.Gh)

with potential to create sustainable competitive advantage. Recent marketing research shows that brand awareness is not a mere cognitive measure. It is in fact correlated with many valuable dimensions such as customers' 'selves' and brand engagement. Brand personality carries self-like attribute and is not only measured at the individual level, but has become a collective phenomenon.

In consumer behaviour studies, quite a substantial amount of research works have been devoted to brand personality, and discusses the set of human characteristics that are associated with brand (Aaker, 1997). Many authors have emphasized on how the personality of a brand helps customers to identify their own self (Belk, 1988 as cited by Aaker, 1997), an ideal self (Malholtra, 1988 as cited by Aaker, 1997) or specific dimensions of their selves (Kleine et al., 1993 as cited by Aaker, 1997) and their engagement with the brand. Industry players see brand as a means to differentiate product category (Halliday, 1996 as cited by Aaker, 1997), as a central driver of customer preference and usage (Biel, 1993 as cited by Aaker, 1997), and as a common denominator that can be used to promote an organisation across cultures (Plummer, 1985 as cited by Aaker, 1997) through self congruent and engagement with a brand. Notwithstanding, studies on brand personality and the symbolic use of brand to achieve customers' brand engagement have remained limited to some sectors due to less understanding of particular customer group's self-concept. Motivated by this proposition, many authors have argued that, the greater the congruity between the human characteristics that consistently and distinctively describe an individual's actual or ideal self and those that describe a brand, the greater the preference for the brand. However, the empirical exploration of this hypothesis has been handicapped by a limited conceptual understanding of the brand personality construct and the psychological mechanism by which brand operates.

In the works of Seimiene and Kamarauskaite (2014), brand personality is important to achieve brand loyalty, formation of favourable attitudes towards a particular brand, and effort to enlarge brand equity. These authors found that, brand personality are mostly impacted by design of bottle and label, design colours, and advertisement. Sheena G. Naresh studied into the importance of brand personality found that, brands are the direct result of the strategy of market segmentation and product differentiation. She concluded that the varying customer demand is evident in all brands ranging from cars customers drive to the food they take. Naresh emphasised that, brand aware interest in customers on the basis of the personalities they hold. Brands also have their distinct personalities that appear to customers in a different way in varied situations. In 2012, Goldsmith and Goldsmith also indicated that, most researchers of brand argue that brand personality plays an important role in generating customer engagement with a brand. These authors have indicated that anecdotal evidence and logical arguments support this assertion, researchers have published few empirical studies to verify this assertion. Their study has showed that brand personality is related to brand engagement for specific brands. Das, Prakash and Khattri have emphasised that, branding establishes visual standards for and viewed brand personality as a way to express personalities and define lifestyles through material possessions. The human like traits found in brands help customers to establish brand connection. Indeed, marketers strive to make their brands seem like its customers own. Brand personality gives a brand a face and customers base their decision not only on the differentiating and functional position, but also on the likeable personality.

Han and Park investigated the effect of brand personality on brand asset management by using the concept of customers' identification with a brand. Their results showed that there are positive relationships between attractiveness, distinctiveness, and self-expressive value of brand personality. The relationships had statistical significant effect on word-of-mouth reports and an indirect effect on brand loyalty. In their work, one important finding was clear that high self-expressive value and high distinctiveness of brand personality makes customers evaluate the attractiveness of brand personality. In another study, Diamantopoulos, Smith, and Grime investigated the impact of Land Rover brand extensions on brand personality using Aaker's measurement scale and found no significant changes in brand personality as a result of brand extension introduction. Park and Lee examined the congruence between brand personality and self-image influence on brand loyalty through intermediate variables of consumer-brand relationship and satisfaction. They found that, the congruence between brand personality and self-image increases not only consumer satisfaction but also the consumer-brand relationship. The authors identified that, for high involvement products the consumer-brand

relationship quality mediates the effects of satisfaction on consumers' brand loyalty. However, for low involvement products satisfaction directly influences brand loyalty.

Despite the interest by researchers into brand personality, there are fewer consensuses on brand personality meaning and brand personality application to higher education. As a result, the understanding of how and when brand personality relates to students' personality and thereby influences their preferences has remained hard to pin down (Sirgy, 1982). Some research works have been conducted to develop systematically a reliable, valid, and generalisable scale to measure brand personality, they are often tried outside higher education sector. Currently, researchers rely on measurement scales that tend to be ad hoc or taken directly from personality psychology but not validated in the context of brands (Kassadjan, 1971). As a result, the theoretical generalisability and implications stemming from the findings in the research on the symbolic use of brands are questionable.

Applying Aaker's Brand Personality Scale to this study, a distinct dimension and brand personality can be used as one-dimensional construct to measure brand personality in higher education sector. This means that different types of brand personalities can be distinguished and the multiple ways in which brand personality construct influences students' preference can be understood better. In addition, Aaker's Brand Personality scale can also provide the basis for theory building on higher education symbolic use of brand. In this way, the framework which is credited with its general application shall promote the symbolic use of brand within higher education sector. The symbolic nature of brand can be understood at the same level as the utilitarian nature of brands, which tends to be captured by models that are generalisable across product categories. Therefore, like the multi-attribute model which sheds insight into when and why customers buy brands for utilitarian purposes, a cross-category framework and scale can provide theoretical insights into when and why students buy higher education's brand for self-expressive purposes.

It is in the light of these developments that research into customers' perception on brand personality, self-concept and brand engagement is important. This means that the outcome from this study can contribute to theoretical generalization and managerial implications into the symbolic use of brand.

This paper is structured to look at the different perspectives of brand personality and its measurement in relation to customers' brand engagement and self-concept. The methodology, data analysis and findings, conclusions, and direction to future studies with limitations have been discussed.

## 2. Literature review on hypothesis development

### 2.1 Brand personality

Research in brand in general and brand personality in particular began in the early 1960s. Part of the studies was into the relationship between self-concept and perceived personality of cars. These early researchers were limited in their work because of inadequate common theory and consensual taxonomy of personality attributes to describe products and brands. The validity of the early product personality scales, based on human personality remains questionable because human and product personalities have varied antecedents. Product personality traits can be considered as symbolic consumption of the product through direct and indirect contact.

Aaker (1997) realizing this difficulty and learning from the big five model of human personality came out with brand personality scale which has five generic dimensions: excitement, sincerity, competence, sophistication, and ruggedness. Geuens et al. (2009) also considered the difficulties in the definition of brand personality and human personality traits and developed a new measure for brand personality. Today's customers do not only expect to be romanced by the brands they choose to bring into their everyday lives. Customers prefer to establish a multifaceted holistic relationship with brands that can play positive and proactive role in their lives. The strategic objective of brand personality is to forge strong and meaningful bond with customers and in doing so, become part of their life stories, memories, and an important link in their social networks. In recent years, many brands have adopted

emotional-branding strategies to meet the social and emotional needs of customers. Brand personality tends to provide symbolic and self-expressive function in the minds of customers.

Keller (2001) made brand engagement a key component of his Customer-Based Brand Equity model. Developing scholarly work on his basic concept of brand salience, Keller proposed that managers can take specific steps to create brand equity by connecting with customers and making their brands relevant to their customers' life. Keller emphasised that, active relationship between brand and customer leads to brand engagement with the brand expressed as customer's eagerness to talk about it, learn about it, and exhibit its use (Goldsmith, 2011). The brand management literature is stuffed with recommendations and exhortations advising brand managers to encourage their consumers to become engaged with specific brands (Sullivan, 2009). Being engaged with a single brand, however, might also indicate a general tendency to engage with other brands. This leads to the first hypothesis:

H<sub>1</sub>: Brand Personality dimensions positively affect customers' brand engagement

## 2.2 Customers self-concept

Self-concept is the way people describe themselves based on the roles they play and the personal attributes they think they possess. It is important to acknowledge that, students may not see themselves the way others see them because their values are different. The academic environment can contribute to students' self-esteem which is the level of satisfaction they attached to personal attributes that describe what they think about themselves. Sayid Dabbagh Ghazvini (2011) research showed a close relationship between academic self-concept and measures of academic performance. The study revealed that academic self-concept powerfully and positively predicts general performance in literature and mathematics and recommended that teachers should be offered methodological guidance in educational delivery process. Pesanayi Gwirayi and Almon Shumba (2014) study into students' self-concept and academic achievement indicated that students who reported receiving positive comments from classmates and teachers were more likely to be rated by their teachers as having higher academic achievement compared to those who perceived themselves to be less favourably regarded by teachers. Dramanu and Barlarabe (2013) study in Ghana also indicated positive relationship between academic self-concept and academic performance of students. They found a significant difference between academic self-concept of students in urban and rural Junior High Schools with students in urban schools recording higher scores. These authors concluded that actions and reactions of teachers, parents and significant others towards students should encourage, suggest, assure and reinforce students that they are academically capable and competent. This shows that customers' 'self' affect their associations and what they value. The second hypothesis is:

H<sub>2</sub>: Customers' self-concept positively affects brand engagement

## 2.3 Brand engagement

Customers' brand engagement is one of today's key research issues which is normally understood as psychological process to the formation of loyalty, behavioural manifestation towards brand purchase, and psychological state that is characterized by some level of vigour, dedication, absorption and interaction. Blandina Sramova (2015) did a study on Slovak University students about their brand engagement. The research showed that, what predict students' brand engagement are factor power, benevolence, hedonism and self-determination. Slovak University's students attach engagement to brands according to display of certain power which may be related to satisfaction of social needs with emphasis on interpersonal relationships. The students' perception on their engagement of brand is associated with lower levels of self-determination, benevolence and higher level of hedonism. This translates to mean that, Slovak students can be engaged to a brand when an organisation emphasised social status and prestige leading to the satisfaction of social contact by highlighting the enjoyment of life and some sensuality with lower levels of independence, freedom, openness, loyalty, responsibility and sense of life. Goetz Greve (2014) did research on the moderating effect of customer engagement on brand image and brand loyalty relationship. The study found that active and passive engagement activity has an impact on brand loyalty, and brand image is negatively moderated by engagement activity. This means that a higher level of engagement can diminish the predominant link of brand image on brand loyalty. In this regards, brand engagement becomes the



product of the interplay between customers' self-concept and what the brand characteristics are. The third hypothesis is that:

H<sub>3</sub>: Brand engagement is affected by customers' self-concept and brand personality characteristics.

### 3. Research methodology

On the basis of research works on brand personality, self-concept and brand engagement, this study has the objective to investigate the effect of brand personality and self-concept on brand engagement. By this approach, the theoretical and practical understanding to brand personality and customers' self-concept on brand engagement can be enhanced.

#### 3.1 Research design

The research data was collected by the use of structured questionnaire made up of three sections. The section A is on brand personality adapted from Aaker's brand personality measurement scale. The measurement scale contains five dimensions, namely sincerity, excitement, competence, sophisticated and ruggedness. The sincerity dimension has eleven (11) items, excitement has eleven (11) items, competence has nine (9) items, sophisticated has six (6) items and ruggedness has five (5) items.

The section B is on students' brand engagement and used an adapted measurement scale developed by Keller. The measurement scale has six (6) items. The section C is on students' self-concept with six (6) items and used an adapted measurement scale developed by Sprott et al.,. The items in the three sections were presented as statements on the questionnaire with rating scales ranging from 1 (strongly agree) to 7 (strongly disagree). The drafted questionnaire were put to test with 30 students and were requested to give their opinion on the state of the questions in the area of clarity, omissions and errors. The feedbacks received were on the number of questions involved which translates to more time needed for completion, and clarity of some items. Number of questions could not be reduced due to the research scope but action was taken on the clarity of the questions. Subsequently, the revised questions were sent to three faculty members whose specialties are in brand management.

Given the total population of 1400 (Christian Service University College Admissions Office, 2015) and using Krejcie and Morgan (1970) table for determining sample size from a given population, the sample size for this study was set at 302. A total of 302 questionnaires were sent out and the total valid questionnaire received for the study was 252 representing 83.44%. Out of the remaining 50 questionnaires, 30 were not returned and 20 were also not properly completed. One of the key reasons for this shortfall is that, the period of the data collection coincided with examination revision week and most students could not give the due attention to the completion of the questionnaires. Notwithstanding, the 83.44% of a sample size is acceptable to research work of this nature (Neuman, 2005). The data was collected using personal contact approach at the University's campus and this is in line with the recommendations by Sureshchandar et al (2002) that personal contact provides detail engagement to survey.

#### 3.2 Measures

The aforementioned constructs: Aaker's Brand Personality scale (1997), Keller's Brand Engagement (2003), and Sprott, D., Czellar, S., and Spangenberg, E. (2009) self-concept were each measured on seven-point Likert scale ranging from 1 (excellent or very well) to 7 (very weak or not at all). Factor analysis was used to assess the three constructs' suitability in Private University students' context (Lavee, 1988; Byrne, 2001). The study has also verified the variables in the Brand Personality scale to determine its relationship with students' self-concept and brand engagement using structural equation model.

### 4. Data analysis and findings

The first step was to enter the data into SPSS 20.0 and checked for incorrect entries and missing data. A series of exploratory factor analysis (EFA) were performed to purify the scales, evaluate their internal consistency, and assess their discriminant validity. A test of reliability was conducted to

measure the reliability of each measurement item. Cronbach's alpha values exceeding or very closed to 0.6 cut-off as recommended by Hair et. al. (2010) was used in the study. The principal component analysis method was used in this study to locate the underlying dimensions of the brand personality, self concept and brand engagement. The objective of the principal component analysis was to derive a relatively rich and manageable number of factors that capture as much information as possible in the observed variables (Leech et al, 2011). The factor scores for each dimension can be used in further analysis including regression to lessen multicollinearity problem.

Within the brand personality construct, some items loaded onto more dimensions and this led to some items' deletion. As regards sincerity dimension, two items ('this university brand is ordinary' and 'this university brand is Kumasi-base') were deleted due to their poor loading. Three sincerity items ('this university brand is happy', 'this university brand is over-romantic' and 'this university brand is friendly') were also loaded onto completely new dimension. This new set of items were categorised as 'Hedonism'. Out of the 11 items under excitement dimension, only 4 items loaded well on the factor matrix. The excitement items that loaded well on the factor matrix were 'this university brand is fashionable', 'this university brand is exciting', 'this university brand is creative', and 'this university brand is unique'. Competent dimension has nine (9) items as identified by Aaker (1997), eight (8) loaded well on the factor matrix. In addition, two ruggedness items ('this university brand is religious' and 'this university brand is strong') also loaded onto the competent dimension. Out of the six (6) items that measure sophisticated dimension, three (3) loaded well onto the factor matrix.

Keller and Sprott et al used unidimension to measure brand engagement and brand self-concept respectively. The study has revealed that, the six (6) items measuring each of these dimensions can be divided to achieve better insight of the dimension for theoretical and managerial decisions. The factor matrix successfully loaded three (3) items each onto different dimension to measure particular construct. Under brand engagement, 'students like to talk about their university', 'students are always interested in learning more about their university', and 'students are interested to wear cloth with their university's brand name on it', were dubbed 'Ambassador'. The other three items namely 'students are proud to have others know that they attend a particular university', 'students always visit their university's website', and 'students closely follow news about their university's brand' were categorised as 'Identification'.

With regard to self-concept, 'students have special bond with their university's brand that they like', 'students often feel personal connection between their university brand and themselves', and 'students feel as if they have a close personal connection with their university brands they most prefer' were classified as 'self-congruence'. The other three items: 'students can identify with important university brands in their lives', 'there are links between university brands that students prefer and how they view themselves', and 'students favourite university brands are an important indication of who they are', were named as 'value-congruence'. The Cronbach's alpha values for these dimensions were impressive.

Based on estimated reliability coefficients, it was apparent that the adapted brand personality, brand engagement, and self-concept scales were highly reliable instrument. Table 1 below gives the reliability results.

Table 1: Reliability results for brand personality, brand engagement and self-concept scales

S/N	Dimension	Number of Items	Cronbach Alpha
			Brand Personality scale
1	Sincerity	6	0.898
2	Competent	10	0.939
3	Sophisticated	5	0.819
4	Excitement	4	0.814
5	Hedonism	3	0.790
	Brand Engagement scale		
1	Ambassador	3	0.782
2	Identification	3	0.862
	Self-Concept scale		

1	Self-Congruence	3	0.853
2	Value-Congruence	3	0.861

Following concerns regarding research that deploys self-report instruments such as questionnaires as used in this study as a possible source of bias, it became expedient for the researchers to assess the presence of common method bias (CMB) in the study (Podsakoff et al., 2003). A method-only model was estimated by linking all the measures to a single factor. The analysis yielded poor model fit indices and therefore a conclusion was reached that CMB does not largely describe the data used in the study and as such there is no problem in the study.

#### 4.1 Results

Stata 13 was used to undertake the regression and structural equation model analysis. The resulting regression analysis indicated that, 53.70% of brand engagement variance can be explained by self-concept and brand personality.

However, changes in self-concept and brand personality can cause brand engagement to change by 56.67% and 33.78% respectively. It can be seen from the regression analysis that, the proposed relationship between brand engagement on one hand and self-concept and brand personality on the other is positive. The results indicated that there are statistically significant difference between brand engagement, and self-concept and brand personality ( $F=144.41$ ,  $p=0.00$ ). This has supported the study's hypothesis  $H_3$ .

The study investigated the effect of brand personality dimensions on students' self-concept and students' brand engagement. Looking at the effect of brand personality dimensions, 43.84% of self-concept variance can be explained by brand personality dimensions. Competence and excitement showed positive relationship with self-concept and were significant. Changes to competence and excitement can cause 56.39% and 15.76% to students' self-concept respectively.

The brand personality dimensions with significant effect on self-concept are competence ( $F=38.40$ ,  $p=0.000$ ) and excitement ( $F=38.40$ ,  $p=0.023$ ). Sincerity ( $F=38.40$ ,  $p=0.459$ ), Sophisticated ( $F=38.40$ ,  $p=0.332$ ) and Hedonism ( $F=38.40$ ,  $p=0.653$ ) do not have significant effect of self-concept. Interestingly, sincerity and hedonism showed negative relationship to students' self-concept.

Perhaps in the faith-based university setting, students are not keen in pleasure-seeking and the self-gratification character of the brand. In addition, sincerity in academic environment may also introduce negative perception among students. This situation attests that, brand's personality dimensions may relate differently to customers. This supports our hypothesis  $H_2$ .

The study has also revealed that 37.23% variance in brand engagement can be explained by brand personality dimensions. Competence ( $F=29.19$ ,  $p=0.002$ ), sophisticated ( $F=29.19$ ,  $p=0.001$ ) and excitement ( $F=29.19$ ,  $p=0.010$ ) have significant effect on brand engagement. This means that, Private Universities can use competence, sophisticated and excitement to improve on students' brand engagement and to differentiate itself from the competition.

Again, sincerity has showed negative relationship and still not significant. This also supports our hypothesis  $H_1$ . The tables 2 and 3 below show the summary of the regression information on Brand Engagement, Brand Personality and Self-Concept constructs.

Table 2: Summary of regression information on brand engagement, brand personality and self-concept constructs

Constructs	Degree of Freedom	F - Value	R - Squared	Adjusted R - Squared	Significant Value
Self-Concept and Brand Personality effect on Brand Engagement	2,249	144.41	0.5370	0.5333	0.000
Brand Personality Dimensions effect on Self-Concept	5,246	38.40	0.4384	0.4270	0.000
Brand Personality Dimensions effect on	5,246	29.19	0.3732	0.3596	0.000

Brand Engagement

Table 3: Summary of Regression Information on Brand Personality Dimensions, Brand Engagement and Self-Concept Constructs

Concepts/Dimensions	Coefficient Values	Standard Error	T – Value	P - Value
<b>Brand Engagement</b>				
Self-Concept	0.5667	0.5534	10.24	0.000
Brand Personality	0.3378	0.0659	5.12	0.000
<b>Self- Concept</b>				
Competence	0.5639	0.07565	7.45	0.000
Sincerity	-0.05822	0.78588	-0.74	0.459
Sophisticated	0.06875	0.07073	0.97	0.332
Excitement	0.15757	0.68821	2.29	0.023
Hedonism	0.02839	0.06314	-0.45	0.653
<b>Brand Engagement</b>				
Competence	0.25576	0.08367	3.06	0.002
Sincerity	-0.02635	0.08903	-0.30	0.762
Sophisticated	0.25949	0.07823	3.32	0.001
Excitement	0.19632	0.07611	2.58	0.010
Hedonism	0.03637	0.06983	0.52	0.603

4.2 Testing structural relationships using SEM

Structural equation modeling was used to estimate parameters of the structure model to specify the relationships among brand personality, self-concept and brand engagement using Stata 13. The model specifies sincerity, competence, sophisticated, excitement and hedonism as exogenous constructs to brand personality. Ambassador and identification were also classified as exogenous constructs to brand engagement. In addition, self-congruence and value-congruence were also indicated as exogenous constructs to self-concept. In turn, brand personality and self-concept were also stated as exogenous construct and were directly related to brand engagement.

The results initially suggested that our data did not fit well with the theoretical structure of the construct. Although there is no universally agreed standard for assessing the quality of structural equation models, the conventional approach has been to examine a basket of criteria against a set of rule-of-thumb acceptable levels. The structural equation model is expected to show a reasonably small error in relation to its complexity. RMSEA should be low (RMSEA < 0.08), Tucker-Lewis Index (TLI) and Normed Fit Index (NFI) should be high (TLI and NFI > 0.90), Standardised Root Mean Squared Residual (SRMR) should be low (SRMR < 0.05), and Comparative Fit Index (CFI) should be high (CFI > 0.90) (Bentler, 1990; Joreskog, 1978; Kline, 2005). In line with this conventional approach, the measurement model for brand engagement exhibited relatively poor fit as RMSEA was 0.110. However, the CFI, TLI and SRMR are within acceptable ranges (see appendix 4). The reasons for this moderate model fit may be that, students from faith-base Private Universities do not appreciate the

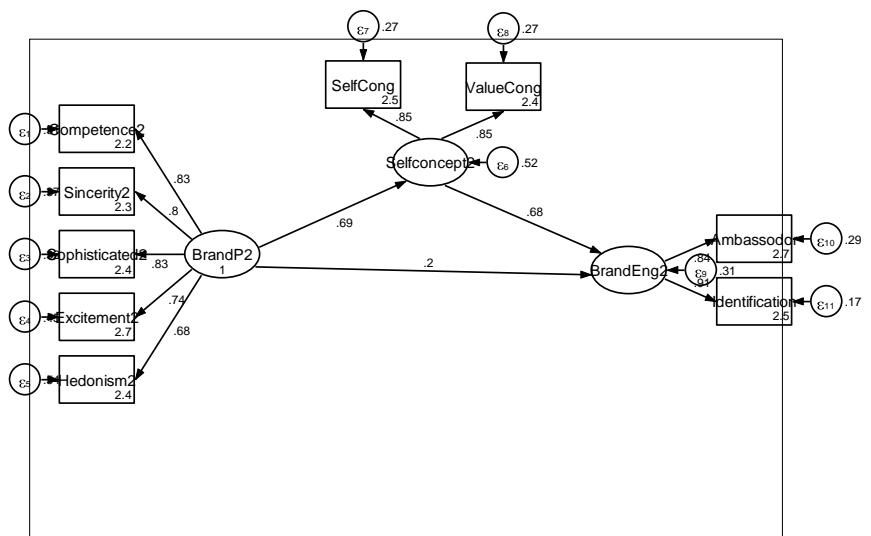

Figure 1: Initial structural equation model for brand engagement, self-concept and brand personality



hedonism part of brand personality and that brand personality does not directly relate well to brand engagement. The initial model is showed in figure 1.

Using the same technique but by relaxing on hedonism and relating brand personality directly to self-concept and self-concept directly to brand engagement, the modification improved the model construct structure. The RMSEA improved significantly (0.088) and all the other constructs showed improvement. Thus, the CFI has changed from 0.9 to 0.972, TLI improved from 0.9 to 0.957, and SRMR has reduced from 0.044 to 0.037 (see appendix 5). Their respective factor loadings have also improved. The new structural relationship is showed in figure 2 below.

From figure 2 above, the loading has improved indicating that the deletion of hedonism and the direct relationship between brand personality and brand engagement through self-concept is the reason. The study therefore concludes that brand personality affects self-concept and this also affect brand engagement. This means that, hedonism does not affect faith-based Private Universities' brand personality. In addition, achieving brand engagement requires aligning brand personality dimensions, especially competence and excitement to students' self-concept. The table 4 below shows the initial and final fit statistics information.

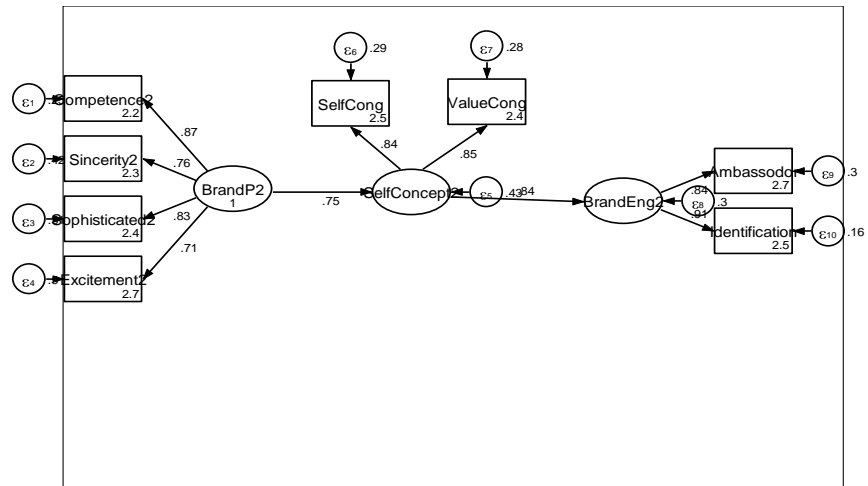

Figure 2: Final structural equation model for brand engagement, self-concept and brand personality

achieving brand engagement requires aligning brand personality dimensions, especially competence and excitement to students' self-concept. The table 4 below shows the initial and final fit statistics information.

Table 4: Fit statistics

Description	Values	
	Initial Statistics	Final Statistics
Chi Square	97.519	52.937
P – Values	0.000	0.000
Root Mean Squared Error of Approximation	0.110	0.088
Comparative Fit Index (CFI)	0.948	0.972
Tucker-Lewis Index (TLI)	0.922	0.957
Standard Root Mean Squared Residual	0.044	0.036

### 5. Conclusions

This study has the objective to investigate the impact of brand personality and self-concept on brand engagement. To achieve this objective, the research appraised all the measurement scales of the said constructs to determine their measurement value in the study context for theory and managerial practices.

The study found that, brand personality can be adequately measured using sincerity with 6 items, excitement with 4 items, sophisticated with 3 items, competence with 10 items, and hedonism with 3 items totaling 26 items. This is an improvement over Aaker's brand personality scale of 42 items. The identification of hedonism dimension is significant as brand has pleasurable seeking value that is important to customers. The study has split brand engagement into ambassador and identification as well as that of self-concept into self-congruence and value-congruence. This has improved the theoretical development of brand engagement and self-concept constructs for management decision making.

The study found that, brand personality has direct effect on self-concept and in turn affect brand engagement. The direct effect on brand personality on brand engagement is minimal. This shows that, self-concept is important to brand engagement success.

Lastly, successful differentiation strategy can be achieved by faith-based Private Universities through competence, sophistication and excitement of programmes and other educational services.

## **6. Managerial and policy implications**

The major conclusion from our study is that, for predictive purposes managers should focus on brand personality through self-concept to achieve customers' brand engagement. As regards specific items to improve brand personality, managers can add hedonism in study settings that are not faith-based (see appendix 6). This means that, sincerity, excitement, competence, sophisticated and hedonism provides adequate satisfactory measurement to brand personality in higher education. In addition, managers can assess their customers' self-concept with respect to their brands by using self-congruence and value-congruence dimensions. Brand engagement measurement can also be done by managers by using ambassador and identification role of customers.

Policy makers should not overlook the students' 'self' development in educational curriculum and this can lead to educational performance as found by Blandina Sramova (2015) and improve brand engagement. In this regard, branding at national and corporate level must consider customers' 'self' for successful engagement.

The new set of items and dimensions found in this study must be used in different research environment particularly in the non-faith-based higher education sector to ascertain their consistency and variations.

## **7. Direction to future studies with limitations**

This research has provided additional insight into brand personality, self-concept and brand engagement measurement. To date, most of the studies in these areas do not focus on higher education sector. The present findings suggest that brand personality can be measured by five dimensions: sincerity, excitement, competent, sophisticated and the newly found dimension hedonism. Self-concept can be measured by self-congruence and value-congruence, while that of brand engagement can be measured by ambassador and identification. However, caution is needed in generalizing the findings although considerable evidence of relative efficacy has been found in the modified constructs. The present study is limited to faith-based Private University students and the assertion needs to be validated by further studies in different University settings and other customers. Further research should use different measurement scales in brand personality, self-concept and brand engagement to find how consistent the results shall be.

## **References**

- Aaker, J. L., (199). Dimensions of brand personality. *Journal of Marketing Research*, 34: 347-356
- Aaker, J. L., (1999). The malleable self: The role of self-expression in persuasion. *Journal of Marketing Research*, 36: 45-57.
- Anderson, J. C., and Gerbing, D.W., (1988). Structural Equation Modeling in Practice: A Review and Recommended Two Step Approach. *Psychological Bulletin* 103 (3): 411-423.
- Ang, S. H., and Lim, E. A. C., (2006). The influence of metaphors and product type on brand personality perceptions and attitudes. *Journal of Advertising*, 35(2): 39-53.
- Austin, J. R., J. A., Siguaw, and Mattila, A.S., (2003). A Re-Examination of the Generalizability of the Aaker Brand Personality Measurement Framework. *Journal of Strategic Marketing* 11 (2): 77-92.
- Azoulay, A., and Kapferer, J. N., (2003). Do brand personality scales really measure brand personality? *Brand Management*, 11: 143-155.
- Bagozzi, P. R., and Yi, Y., (2012). Specification, evaluation, and interpretation of structural equation models. *Academy of Marketing Science*, 40(1): 8-34.
- Berry, L. L. (2000). Cultivating service and brand equity. *Journal of the Academy of Marketing Science*, 28 (1): 128-37
- Byrne, B. (1998). *Structural Equation Modeling with LISREL, PRELIS, and SIMPLIS: Basis Concepts, Applications, and Programming*. Mahwah, NJ: Lawrence Erlbaum.
- Caprara, G. V., Barbaranelli, C., and Guido, G., (2001). Brand Personality: How to Make the Metaphor Fit?. *Journal of Economic Psychology* 22: 377-395.

- Chaudhuri, A., and Holbrook M.B., (2001). The Chain of Effects from Brand Trust and Brand Affect to Brand Performance: The Role of Brand Loyalty. *Journal of Marketing* 65 (April): 81–93.
- Chernatony, L., and Drury, S. (2004). Identifying and sustaining services brands' values. *Journal of Marketing Communications*, 10 (2): 73-93.
- Diamantopoulos, A., Smith, G., and Grime, I., (2005). The Impact of Brand Extensions on Brand Personality: Experimental Evidence. *European Journal of Marketing* 39 (1/2): 129–149.
- Dramanu B.Y., and Balarabe (2013). Relationship between academic self-concept and academic performance of Junior High School students in Ghana. *European Scientific Journal*, Vol. 9, No. 34: 93-104.
- Geuens, M., Weijters, B., and Wulf, K.D. (2009). A new measure of brand personality. *International Journal of Research in Marketing*, Vol. 26: 97-107.
- Ghazvini, S.D., (2011). Relationship between academic self-concept and academic performance in high school students. *Procedia Social and Behavioural Sciences* Vol. 15: 1034-1039.
- Goldsmith, R.E and Goldsmith, E.B., (2012). Brand personality and brand engagement. *American Journal of Management*, Vol. 12(1): 11-20.
- Gwirayi P., and Shumba, A., (2007). Students' self-concept and academic achievement in Zimbabwe: A preliminary study. *Journal of Psychology in Africa*, Vol. 17, Issue 1-2: 119-122.
- Hair Jr. F. J., Black, C. W., Babin, J. B. and Anderson, E. R., (2014). *Multivariate Data Analysis*. (7th Edition). Edinburgh Gata, Harlow: Pearson.
- Keller, K. L., (2003). *Strategic Brand Management: Building, Measuring, and Managing Brand Equity* (2<sup>nd</sup> edn). Upper Saddle River, NJ: Pearson.
- McCrae, R.R., and Costa, P.T. (1987). Validation of the five-factor model of personality across instruments and observers. *Journal of Personality and Social Psychology*, 52: 81-90.
- Podsakoff, P. M., MacKenzie, S. B., Lee, J.-Y., and Podsakoff, N. P. (2003). Common method biases in behavioral research: a critical review of the literature and recommended remedies. *The Journal of Applied Psychology*, 88(5): 879-903.
- Seimiene, E., and Kamarauskaite, E., (2014). Effect of brand elements on brand personality perception. *Social and Behavioural Science* 156: 429-434.
- Sprott, D., Czellar, S., and Spangenberg, E., (2009). The Importance of a General Measure of Brand Engagement on Market Behavior: Development and Validation of a Scale. *Journal of Marketing Research*: February 2009, Vol. 46, No. 1: 92-104.
- Steinman, R. B., (2012). Brand Personality, Brand Transgression and consumer behavior. *International Journal of Business and Commerce*, 2 (1): 76-83
- Vieira, A. L. (2011). *Interactive LISREL in Practice: getting started with a SIMPLIS approach*. New York: Springer.

## Appendix A

Christian Service University College  
Kumasi  
School of Business

### Questionnaire

Dear student,

This study is on the topic “Brand Personality, Self-Concept and Brand Engagement”. It is for academic purposes and responses gathered from you shall be treated with the strictest confidence. In this study, Brand Personality includes all human-like character of a brand and Brand Engagement also include the extent of students' connection to a particular brand. Thank you in advance.

Brand Personality

Kindly circle the number that truly reflects your opinion on the scale from 1 (excellent) to 7 (very weak). There is no right or wrong answer, all that I am interested in is your opinion.

CODE	QUESTION	LIKERT SCALE
------	----------	--------------

		excellent					very weak	
	Sincerity							
Sin 1	How do you rate this University's brand as ordinary?	1	2	3	4	5	6	7
Sin 2	How do you rate this University's brand as Christian-oriented?	1	2	3	4	5	6	7
Sin 3	How do you rate this University's brand as Kumasi-base?	1	2	3	4	5	6	7
Sin 4	How do you rate this University's brand as honest?	1	2	3	4	5	6	7
Sin 5	How do you rate this University's brand as sincere?	1	2	3	4	5	6	7
Sin 6	How do you rate this University's brand as genuine?	1	2	3	4	5	6	7
Sin 7	How do you rate this University's brand as decent?	1	2	3	4	5	6	7
Sin 8	How do you rate this University's brand as original?	1	2	3	4	5	6	7
Sin 9	How do you rate this University's brand as happy?	1	2	3	4	5	6	7
Sin 10	How do you rate this University's brand as over-romantic?	1	2	3	4	5	6	7
Sin 11	How do you rate this University's brand as friendly.	1	2	3	4	5	6	7
	Excitement							
Exc 1	How do you rate this University's brand as bold?	1	2	3	4	5	6	7
Exc 2	How do you rate this University's brand as fashionable?	1	2	3	4	5	6	7
Exc 3	How do you rate this University's brand as exciting?	1	2	3	4	5	6	7
Exc 4	How do you rate this University's brand as spirited?	1	2	3	4	5	6	7
Exc 5	How do you rate this University's brand as cool?	1	2	3	4	5	6	7
Exc 6	How do you rate this University's brand as young?	1	2	3	4	5	6	7
Exc 7	How do you rate this University's brand as creative?	1	2	3	4	5	6	7
Exc 8	How do you rate this University's brand as unique?	1	2	3	4	5	6	7
Exc 9	How do you rate this University's brand as state-of-the-art?	1	2	3	4	5	6	7
Exc 10	How do you rate this University's brand as independent?	1	2	3	4	5	6	7
Exc 11	How do you rate this University's brand as modern?	1	2	3	4	5	6	7
	Competence							
Com 1	How do you rate this University's brand as reliable?	1	2	3	4	5	6	7
Com 2	How do you rate this University's brand as hard working?	1	2	3	4	5	6	7
Com 3	How do you rate this University's brand as secure?	1	2	3	4	5	6	7



Com 4	How do you rate this University's brand as intelligent?	1	2	3	4	5	6	7
Com 5	How do you rate this University's brand as educational?	1	2	3	4	5	6	7
Com 6	How do you rate this University's brand as community?	1	2	3	4	5	6	7
Com 7	How do you rate this University's brand as successful?	1	2	3	4	5	6	7
Com 8	How do you rate this University's brand as leader?	1	2	3	4	5	6	7
Com 9	How do you rate this University's brand as confident?	1	2	3	4	5	6	7
	Sophisticated							
Sop 1	How do you rate this University's brand as upper class?	1	2	3	4	5	6	7
Sop 2	How do you rate this University's brand as attractive?	1	2	3	4	5	6	7
Sop 3	How do you rate this University's brand as good looking?	1	2	3	4	5	6	7
Sop 4	How do you rate this University's brand as polite?	1	2	3	4	5	6	7
Sop 5	How do you rate this University's brand as womanly?	1	2	3	4	5	6	7
Sop 6	How do you rate this University's brand as smooth?	1	2	3	4	5	6	7
	Ruggedness							
Rug 1	How do you rate this University's brand as widely known?	1	2	3	4	5	6	7
Rug 2	How do you rate this University's brand as manly?	1	2	3	4	5	6	7
Rug 3	How do you rate this University's brand as religious?	1	2	3	4	5	6	7
Rug 4	How do you rate this University's brand as strong?	1	2	3	4	5	6	7
Rug 5	How do you rate this University's brand as rocky?	1	2	3	4	5	6	7

#### Brand Engagement

Kindly circle the number that truly reflects your opinion on the scale from 1 (very well) to 7 (not at all). There is no right or wrong answer, all that I am interested in is your opinion.

CODE	QUESTION	LIKERT SCALE						
		very well						Not at all
BE 1	Do you talk about this University with others?	1	2	3	4	5	6	7
BE 2	Do you have interest in learning more about this University?	1	2	3	4	5	6	7
BE 3	Do you have interest to wear cloth with this University's brand name on it?	1	2	3	4	5	6	7
BE 4	Are you proud to have others know that you attend this University?	1	2	3	4	5	6	7
BE 5	Do you always visit this University's website?	1	2	3	4	5	6	7
BE 6	Compared to other people, do you closely follow news about this University's brand?	1	2	3	4	5	6	7

#### Self-Concept

Kindly circle the number that truly reflects your opinion on the scale from 1 (very well) to 7 (not at all). There is no right or wrong answer, all that I am interested in is your opinion.

CODE	QUESTION	LIKERT SCALE						
		very well				Not at all		
BES 1	Do you have special bond with Private University's brand that you like?	1	2	3	4	5	6	7
BES 2	Do you often feel personal connection between Private University brand and you?	1	2	3	4	5	6	7
BES 3	Do you feel close personal connection with Private University brand you most prefer?	1	2	3	4	5	6	7
BES 4	Do you identify with important Private University brands?	1	2	3	4	5	6	7
BES 5	Is there a links between Private University brands and how you view myself?	1	2	3	4	5	6	7
BES 6	Is your favourite Private University brands an important indication of who you are?	1	2	3	4	5	6	7

Student Bio-Data

Please tell me about yourself in terms of.....

1. Programme of study  
(a) Business Studies (b) Arts (c) Theology (d) Applied Science
2. Session you attend  
(a) Day (b) Evening (c) Weekend (d) Sandwich
3. Level or year of study  
(a) L100 (b) L200 (c) L300 (d) L400 (e) Postgraduate
4. Gender  
(a) Male (b) Female